

Intelligent Innovative Interactive

SOLUTIONS

INTELLIGENT
INNOVATIVE
INTERACTIVE

by FROMM
since 1947



The *Intelligent* solutions for:

- Automatic and Semi-automatic Strapping with Steel or Plastic strap
- Automatic Stretch wrapping with Arm and Ring wrapping systems

FROMM | AUTOMATED SOLUTIONS



Further information:
www.fromm-automation.com
www.octomeca.fi

Automated Packaging Solutions
for the **wood industry**

Our portfolio for the wood industry *by FROMM*

The strength of FROMM Automated Packaging Solutions is based on our extensive experience in logistic packaging, since 1947. Our automatic strapping and stretch film systems can easily be integrated into complete packaging lines or work independently. State-of-the-Art 3D technologies, enable customized solutions for any type of industry.

Advantages that bring you the benefits you need and more:

- The best of two worlds; FROMM automated strapping machines and Octomeca* automated wrapping machines.
- The unique range of systems, strapping heads, and film carriers, as well as strap and film types, ensures proper strapping or wrapping for a great variety of applications
- The right packaging for every product: Individually adapted type of packaging for series production or individual packaging.
- Combinations with and integration of all kinds of advanced Robot and Transport technologies.
- Applying corner protectors, bottom, side and top bunks, labels, top sheets, sleeves, curtains, you name it.
- Resulting in excellent pack / pallet stability and a very high level of (stretch) film surface protection and transport security.
- Solutions that you also can easily integrate into existing systems.

10 good reasons to choose FROMM Automated Solutions

1. Solution-oriented consulting by, globally operating, experienced and qualified FROMM experts, giving the best possible solutions.
2. Development of suitable Intelligent concepts, using state-of-the-art software and programming.
3. Complete, robust, highly reliable machines and systems. They meet or exceed the highest quality standards of today's industry.
4. Flexible Integration into existing or new customer systems, creating chains of intelligence and sources information.
5. With innovative 3D detailed design and simulation programs, we ensure that everything fits and works as intended from start-up and afterwards.
6. Rapid system start-up, through Intelligent planning and smooth acceptance procedures. The basis of fast and trouble-free commissioning.
7. Extensive training of customer staff and operators with user-friendly operating instructions that enable your employees to work pleasantly and efficiently.
8. Instruction and planning in prepared maintenance of customer maintenance personnel, with professional project documents and schedules.
9. Interactive remote observation and worldwide delivery of spare parts, aimed at minimizing system downtime due to service and maintenance work.
10. Expansion of system functions through Intelligent accessory technologies and data management.

Industry 4.0 ready

In view of the Industry 4.0 developments, the FROMM Automated Solutions group main tasks focus on:

Consultation

- Consulting services on digitization.
- Actively thinking along with the optimization of production and maintenance processes.

Capture, Analyse and Optimize - for the highest systeme availability

- Planning and design, safety and efficiency of existing and new facilities.
- Optimal visibility into system performance, system status, production and maintenance processes.
- Fast and efficient help with fault diagnosis and rectification.
- Spirit-driven productivity and system availability.

Energy Monitoring

- Monitoring the energy consumption of the system and notification in case of unexpectedly increased consumption.
- Detection of irregularities.

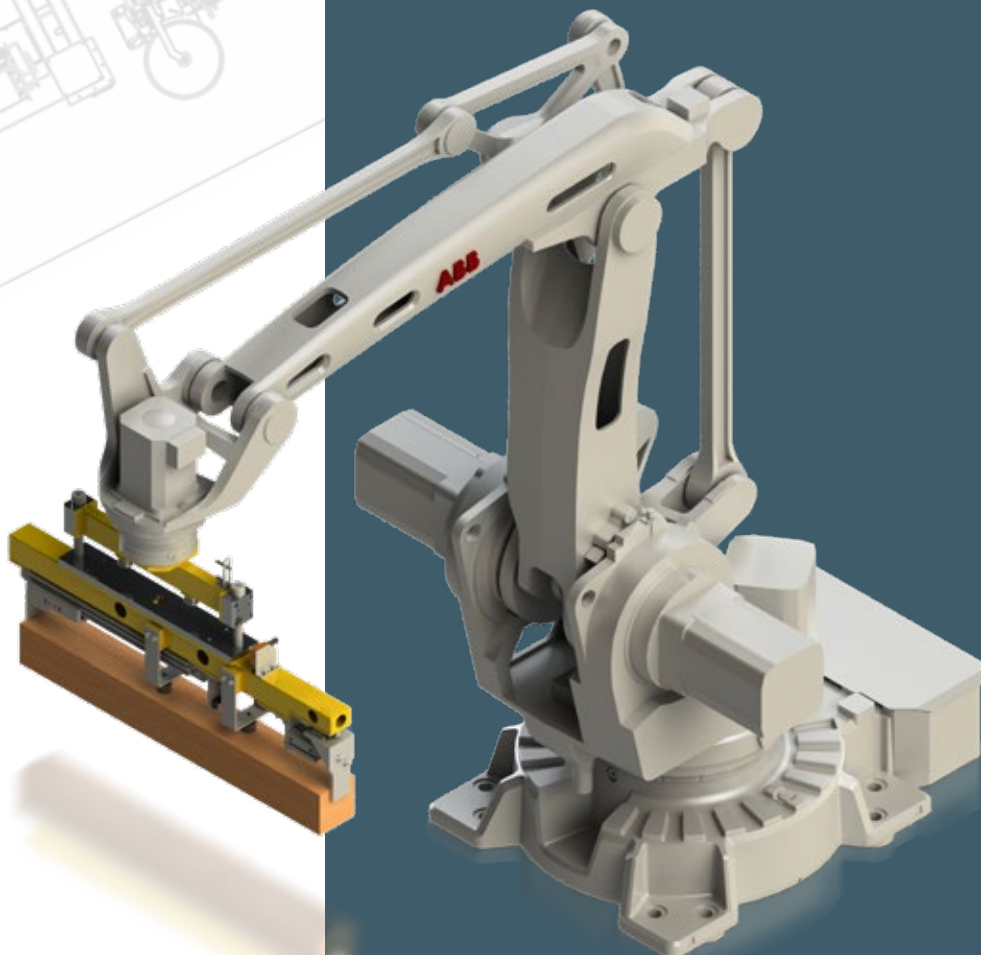

High-quality range

Semi-automatic strapping solutions for plastic and steel straps

The one-operator solution with the use of a FROMM plastic or steel strapping tool.

Seal position: top or side. Defined by the operator.

Strapping types: PP / PET and steel strap

A selection of options: stationary or moving (flexible or fixed positions), with or without sword, pneumatic or electric strap feeding unit, placement of bunks, wood press, top sheet dispenser, tailor made product table, conveyors, multiple dispensers, balancer for the strapping tool.

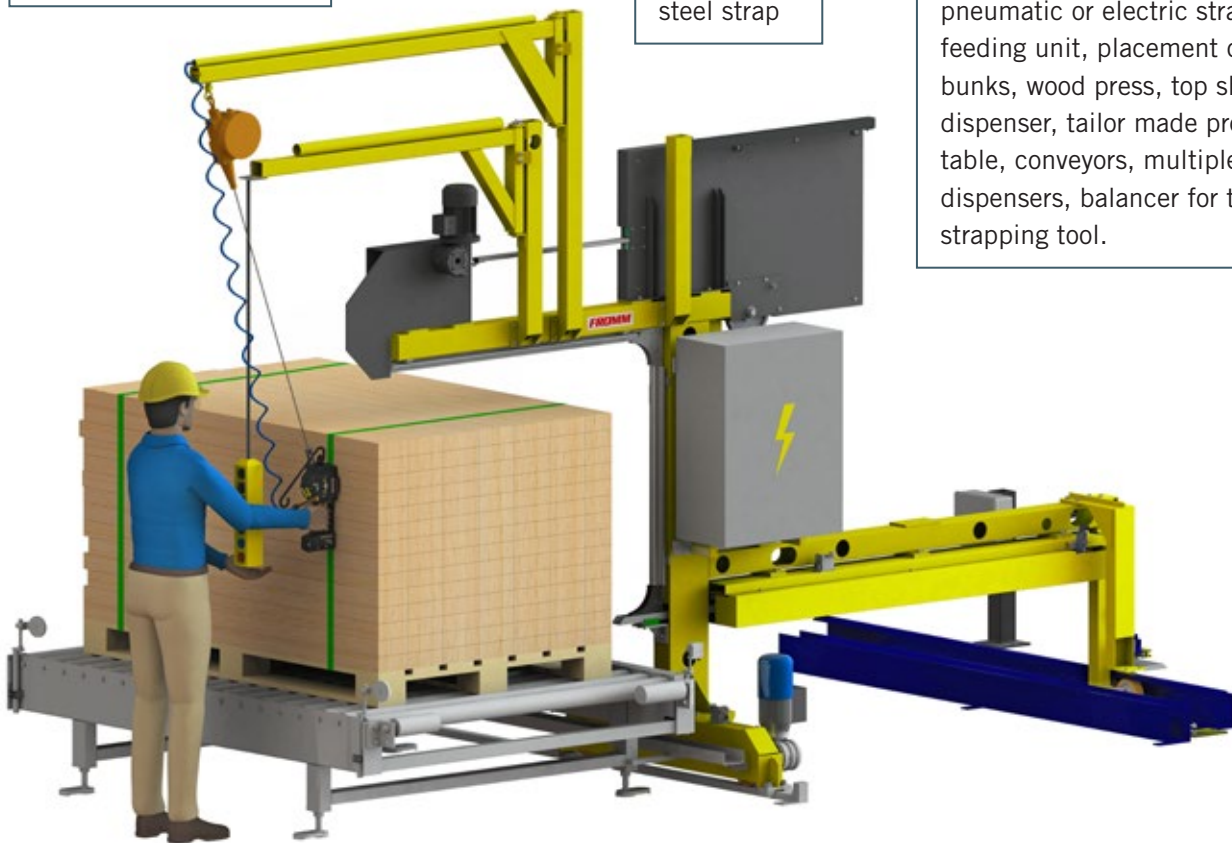

Strapping directions: horizontal, vertical, cross and length

Applications: strapping small series of planks, beams, trunks, poles, plywood, MDF / HDF, plates, lumber, etc.

Packaging examples

Thanks to our market-leading strapping and film protection solutions, our customers' goods are well protected during transport and storage.

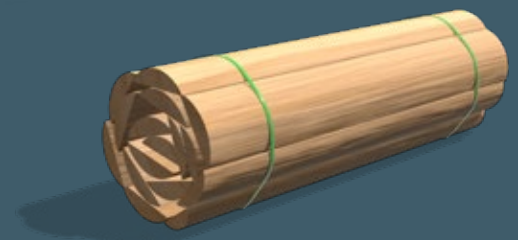

for automatic packa

Fully automated strapping solutions for plastic and steel straps

The wide range of arches, strap dispensers and other options, in combination with the reknown compact, durable and service friendly FROMM heads - with their seal unit positioned off center - enables you to strap all types of large, small and uneven packages in different directions.

Possible positioning of the head: top, side, inclined, horizontal, bottom (customized). Depending on the type of machine, several heads can also be placed for processing plastic strap, steel strap or a combination thereof.

A selection of options: Stationary or moving (flexible or fixed positions) machines, with or without sword, strap dispensers for all viable strap coil types, automatic placement of top, side and bottom bunks, corner protectors at any corner, labelling and inkjet printing, top sheet dispensers, tailor made conveyors, steel / plastic strap combination – multiple heads/dispensers, end of strap detection, wide choice of presses up to 10 tons, ...

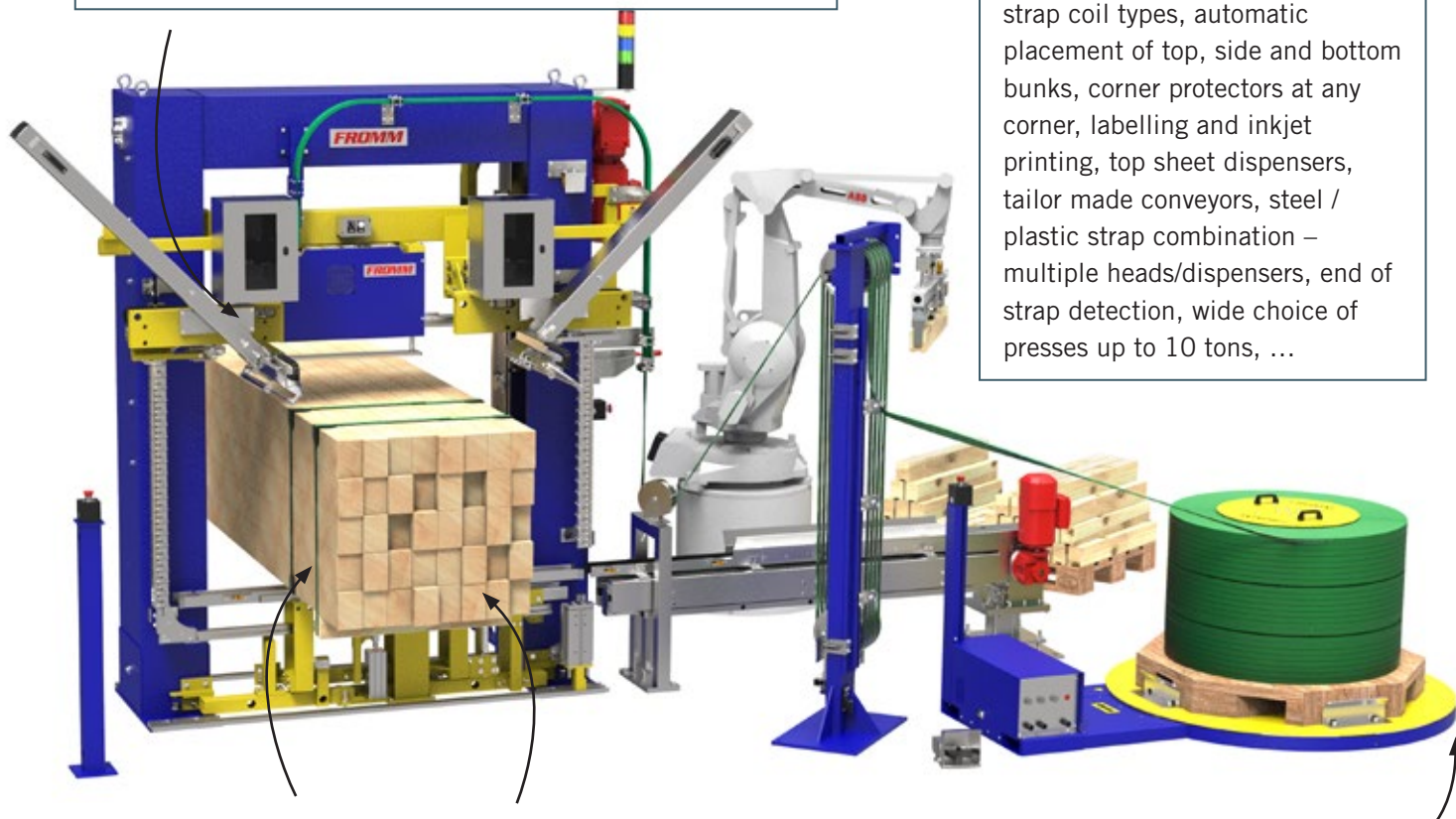

Strapping directions: horizontal, vertical, cross and length.

Applications: Continuous series production of machined or not machined Planks, Beams, Trunks, Poles, Plywood, MDF / HDF, Plates, Lumber, etc.

Strapping qualities: PP / PET or steel strap

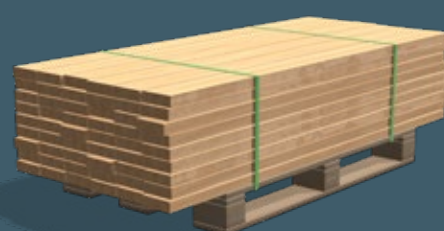
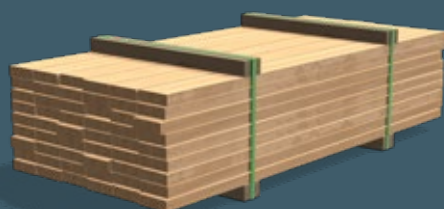

ging by FROMM

Automatic FROMM / Octomeca* Stretch film solutions

The compact and reliable solutions for High Performance horizontal and vertical stretch wrapping.

Our strengths are flexibility and a wide range of optional equipment to achieve the highest level of cargo safety. Octomeca solutions support and can protect your cargo up to 6 sides. We take care of our customers! Complete service for our equipment around the world. Dedicated, to ensuring excellent service life and reliable operation of our solutions.



Possible options: automatic film roll change, roping, film end detection, well-applied cover sheets at front, back, top and both sides, horizontal side wrapping, 6-sided closing, and more.



Some areas of application: Medium to high throughput in continuous packaging, for all sizes and types of machined or unprocessed elements such as: boards, beams, profiles, logs, piles, plywood, MDF / HDF, plywood products, building boards, sawn timber, etc.

Film qualities: Stretch films > 20 µm.
PE flat films for top, front, rear or side application.

Application of stretch film and flat film in different ways and in different directions.

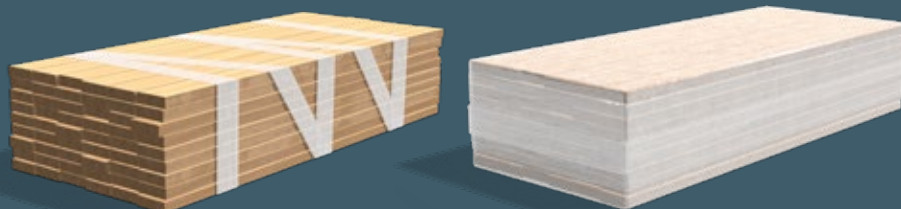

At a glance

Some standard options that go with our Intelligent systems:

Individually selectable, according to your requirements

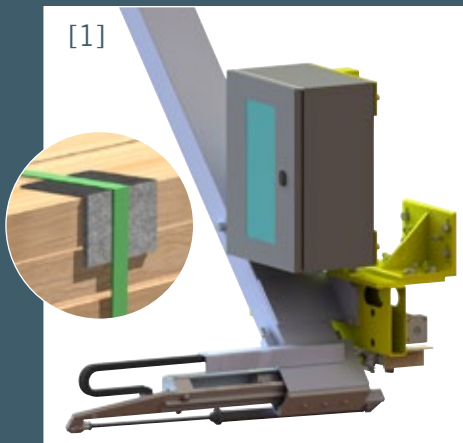

[1] Corner protectors – steel, plastic or carton/paper
Applied automatically at each corner of the package you want to protect against the pressing by straps.

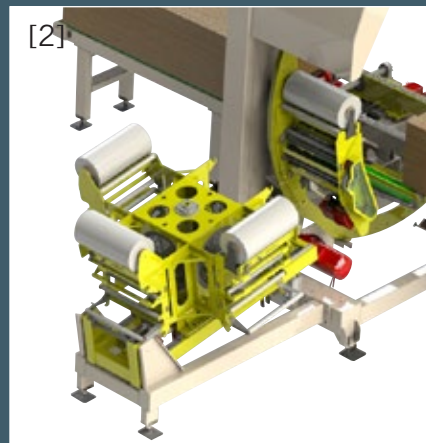

[2] Automatic Film roll change unit – for automatic wrapping machines
Smooth automatic change of film rolls, without human intervention, preventing unnecessary machine downtime.

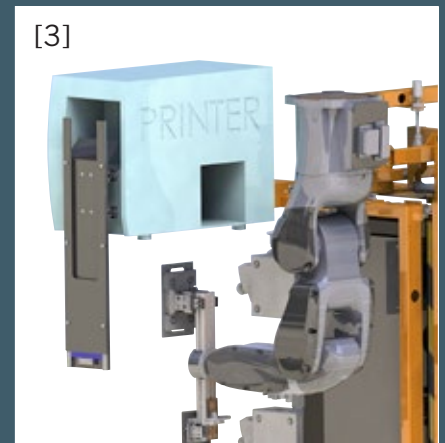

[3] Labels – paper or plastic
Automatic application of (Pre-printed) labels; with the strap or glued onto the package. Placement and printing individually selectable on customer demand.

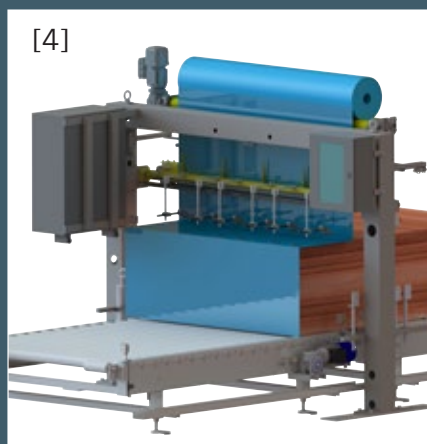

[4] Sheet and sleeve applicators
Automatically placing a plastic top-sheet or side sleeves, to seal the package against moisture, rain or dirt. The applied film can also carry the name of the company.

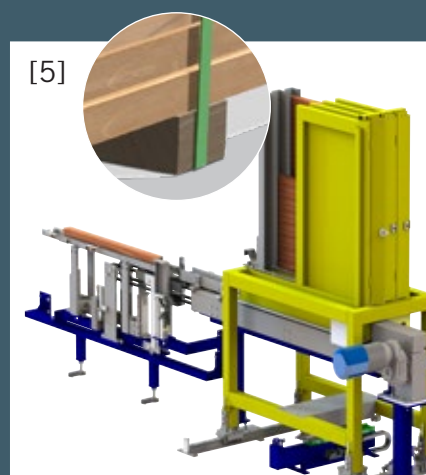

[5] Bunks – top, bottom or side
For an all-round protection and handling of your package. Replacing pallets and manually located frames. Applied automatically with a robot unit or by means of a traditional closed magazine system.

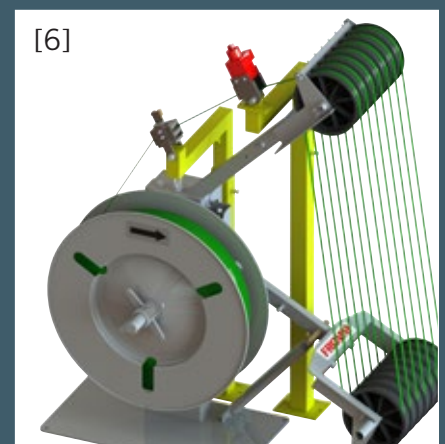

[6] End of Film or Strap signalling – visual, acoustic or electronic warning
Informs the system or the operator direct, to reduce change time of strap or film.

Service *by* FROMM

Think global, act local

We are close to you! Our more than 40 FROMM offices and a large number of specialized long term sales partners worldwide ensure professional advice, qualified customer service, reliable spare parts supplies and maintenance, with quick response times.

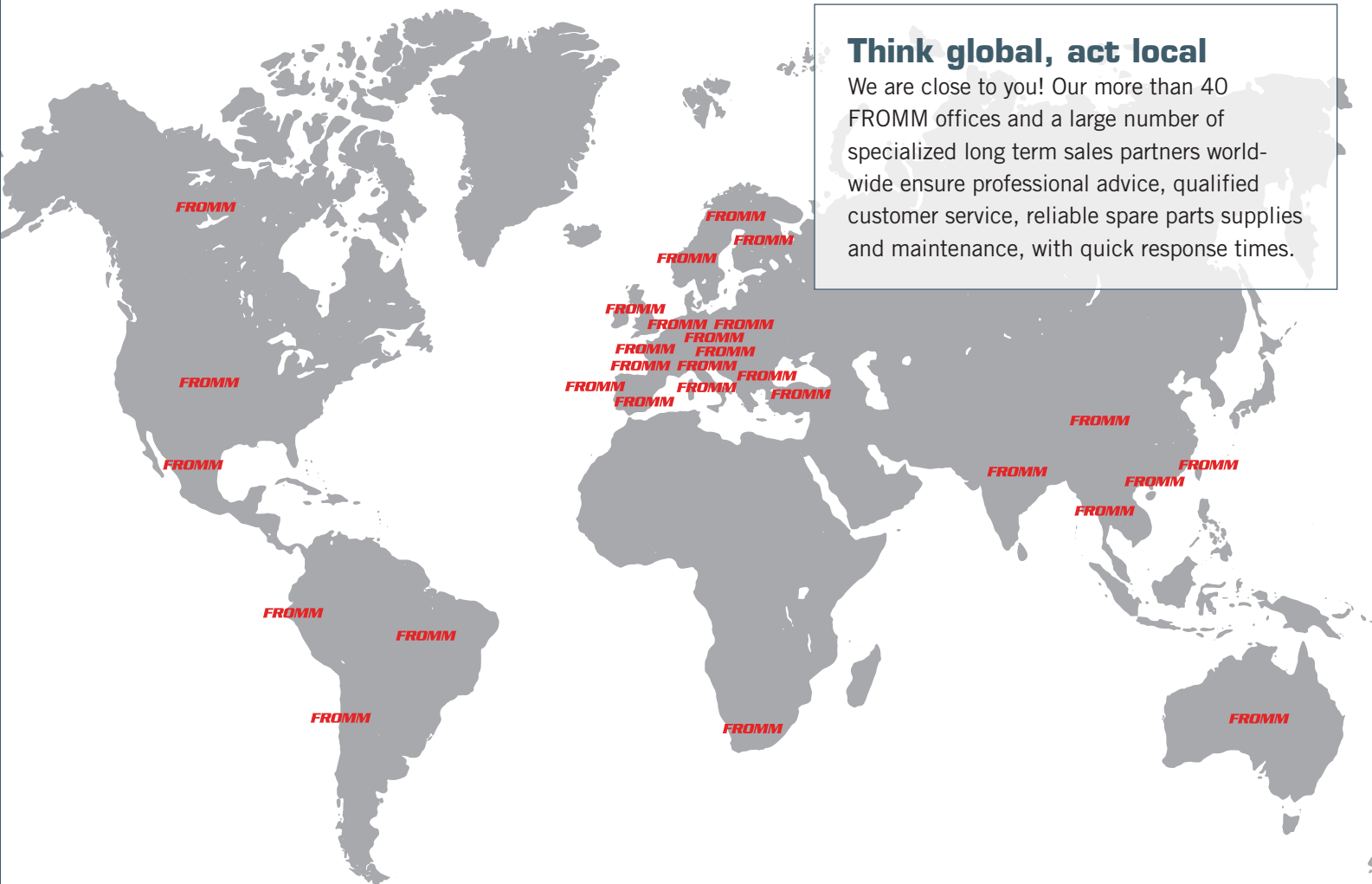

The FROMM product world

FROMM offers you a high-quality, coordinated total package for Strapping and Film Wrapping. Discover our entire product world in our **separate brochures** or speak directly with your **local FROMM partner**.



FROMM Packaging Automation S.r.l. | Viale del Lavoro, 21 a | 37013 Caprino Veronese | Italy | Tel: +39 045 623 05 23 | Fax: +39 04 578 616 03 | fpa.dir@fromm-pack.com
OCTOMECA OY | Linkkikatu 9 | 21100 Naantali | Finland | Tel: +358 2 431 44 09 | omc@octomeca.fi

FROMM | AUTOMATED SOLUTIONS



Further information:
www.fromm-automation.com
www.octomeca.fi

Distributor